

01 ARCHITECTURAL SITE PLAN
SCALE: 1" = 20'-0"

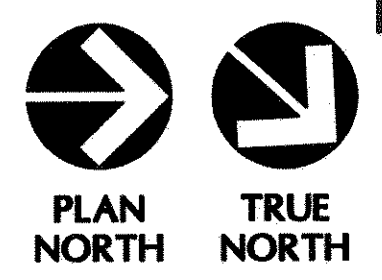

PIPESTONE
(60' R.O.W.)

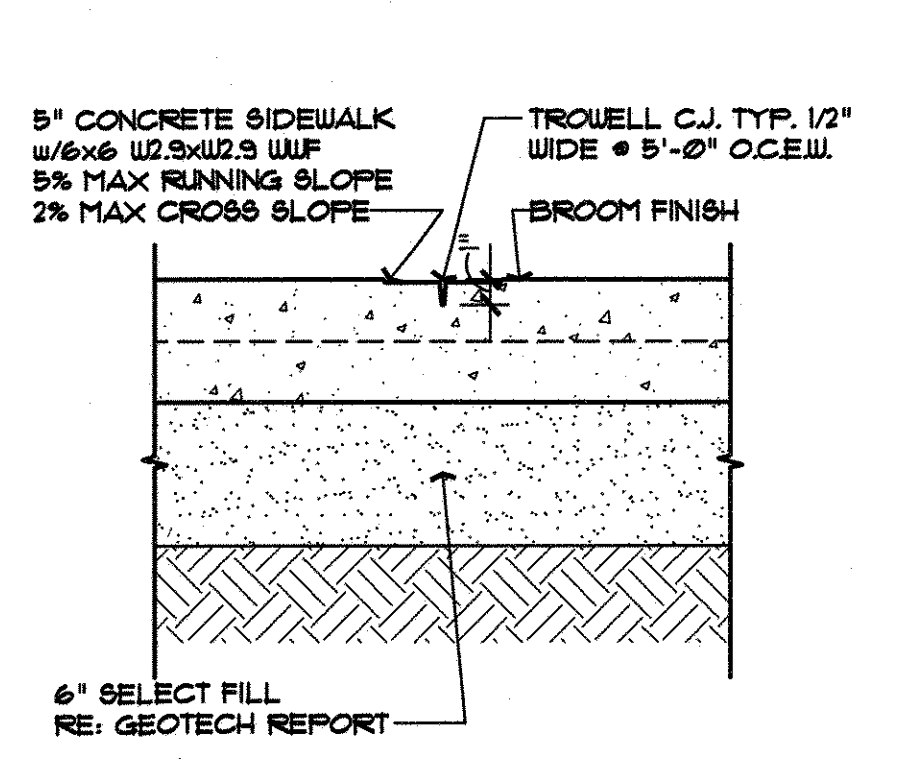

02 TYP. SIDEWALK C.J. DETAIL AT 5'-0" O.C.
SCALE: 1 1/2" = 1'-0"

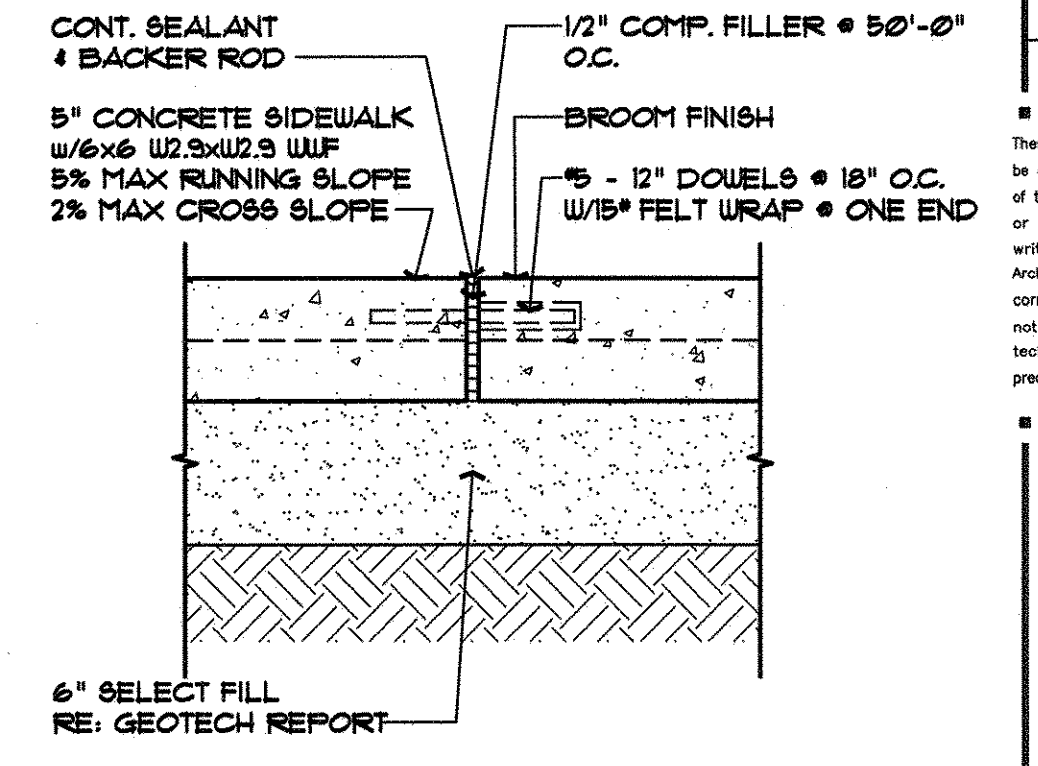

03 TYP. SIDEWALK E.J. DETAIL AT 50'-0" O.C.
SCALE: 1 1/2" = 1'-0"

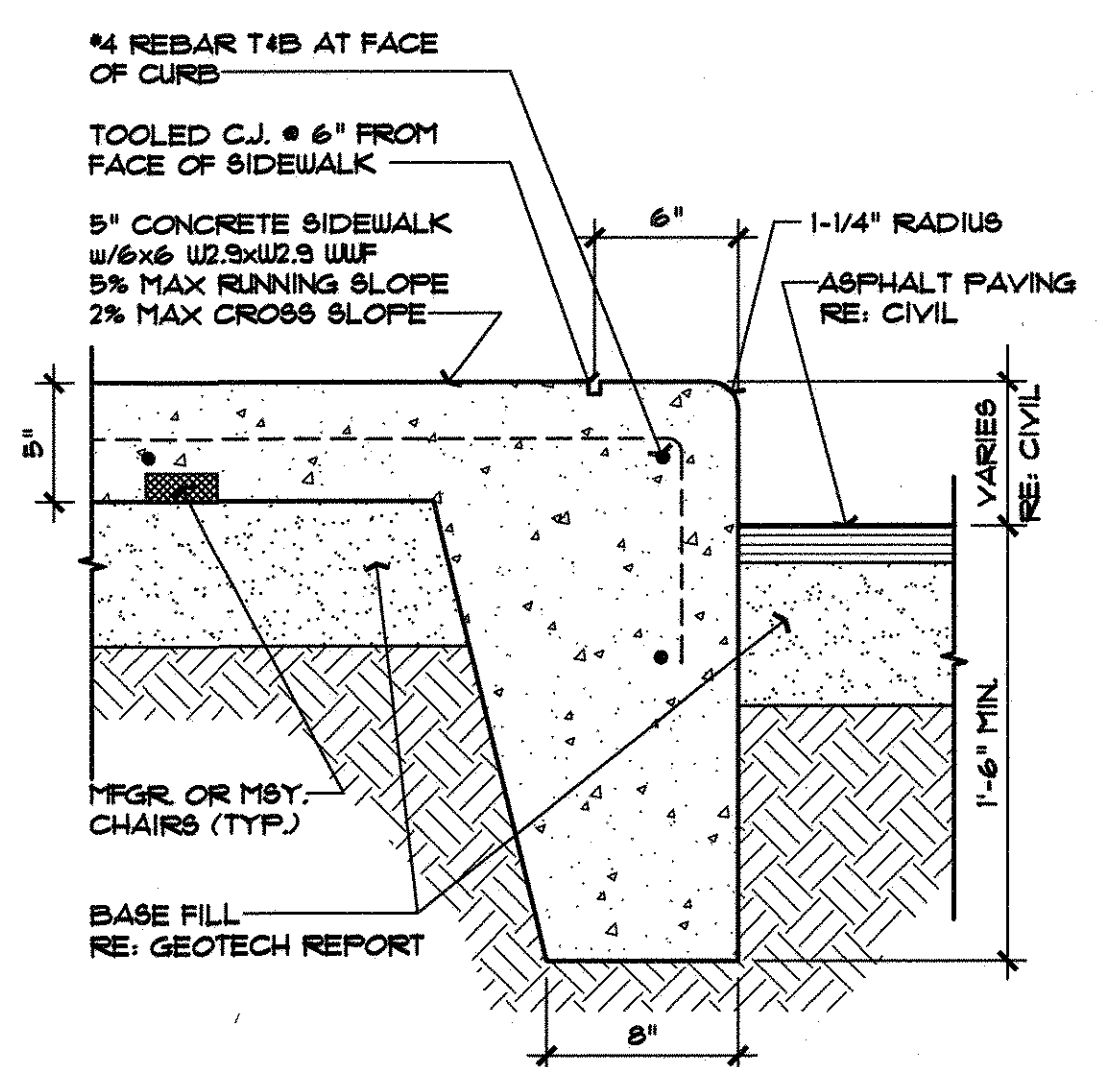

04 CONCRETE SIDEWALK TURNDOWN DETAIL
SCALE: 1-1/2" = 1'-0"

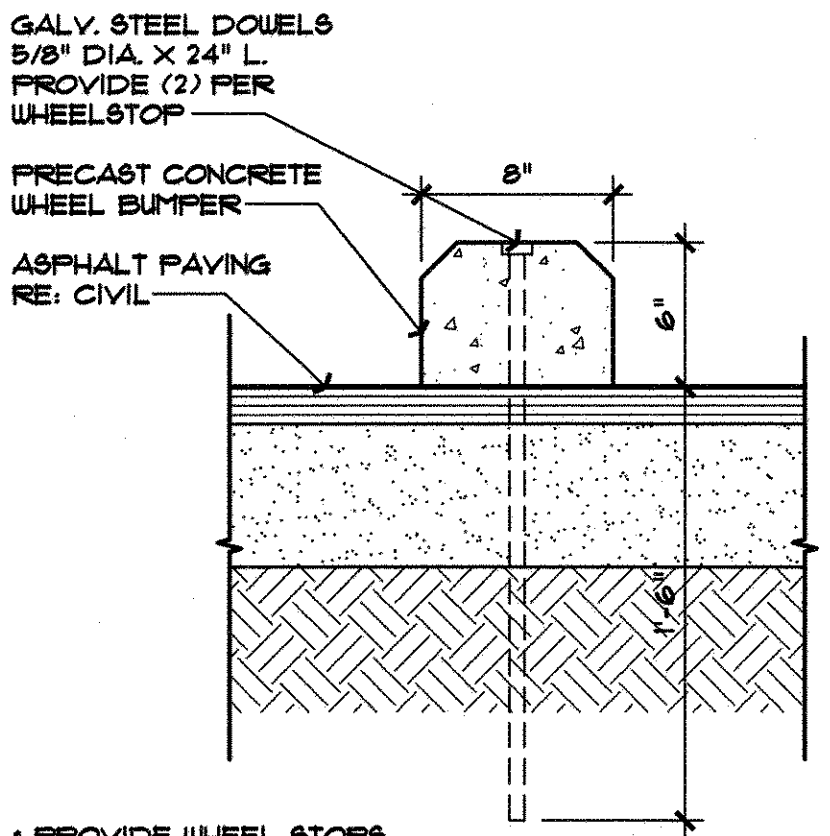

05 CONCRETE WHEEL STOP
SCALE: 1-1/2" = 1'-0"

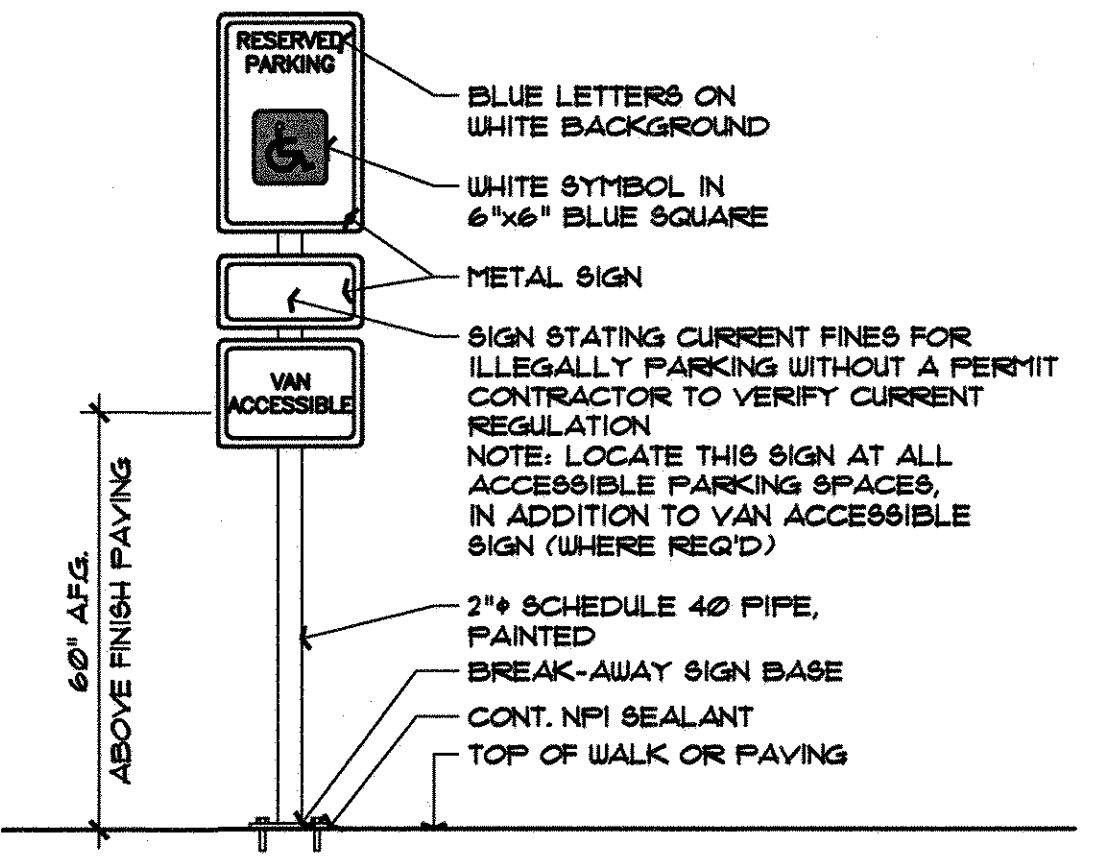

06 HANDICAP PARKING SIGN DETAIL
SCALE: N.T.S.

REVISIONS	DATE	#
BID ADDENDUM	06/01/17	2

300 W. BITTERS ROAD, SUITE 204
SAN ANTONIO, TX 78216
VOICE: (210) 384-8900
FAX: (210) 384-8240
WEB: www.villapark-sa.com
© 2017 ALL RIGHTS RESERVED

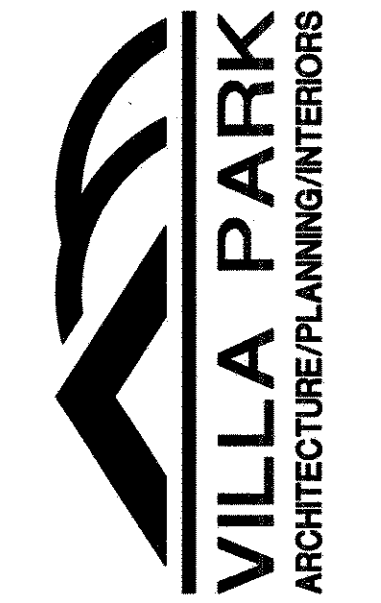

ARCHITECTURAL SITE PLAN
TEXAS PLUMBING SUPPLY
35,100 SF OFFICE/WAREHOUSE BUILDING
17992 RED IRON
SCHERTZ, TEXAS 78154

DRAWN	NPS
CHECKED	JRF
DATE	05/15/17
PROJECT	TEXAS PLUMBING SUPPLY
JOB. NO.	17-100
SHEET	